

JGS5 100W伺服電機 單軸/1-axis

▶ 軌道內嵌
Built-in Guideway

▶ 螺桿驅動
Ball Screw Drive



此圖僅供參考，出貨規格詳見尺寸圖面
The picture is just for the reference. Please check the the actual dimensions on the drawing.

最大行程
Maximum Stroke **800mm**

最高速度
Maximum Speed **1000mm/s**

馬達容量
Motor Output **100W**

滾珠螺桿
Ball Screw **Ø12mm**

型號表示方式 Ordering Method

JGS5 - L5 - 100 - BC - T100W - C4 - MB-3M

本體型號 Model

螺桿導程 Ball Screw Lead

02	02mm
05	5mm
10	10mm
20	20mm

行程 Stroke

50-800mm
50間隔 50 mm Pitch

馬達位置 Motor Position

BC	馬達外露 Motor Exposed
BM	馬達下折 Motor Bottom Side
BL	馬達左折 Motor Left Side
BR	馬達右折 Motor Right Side

電機安裝標準 Motor installation

T	通用馬達安裝標準:
	三菱 Mitsubishi
	台達 Delta
	安川 Yaskawa
	匯川 Inovance
	等等 Etc
P	松下馬達安裝標準

馬達容量 Motor Output

100W	100W
200W	-
400W	-
750W	-

原點感應器 Home Sensor

	外掛型 Out Side
C	馬達側 Motor Side
D	反馬達側 Opposite Motor Side
	無 SENSOR No Sensor
E	無 SENSOR No Sensor

※選擇行程50時，有以下限制：
When the stroke is 50mm, the sensor installation has the following restrictions:
1. 原點與極限需放置於不同側。
Home sensor and limit sensor has to be installed on the different side of body.
2. 滑座左右兩側皆需安裝感應片。
Both sides of slider need to install the sensor trigger device.

端點極限感應器 Limit Sensor

	外掛型 Out Side
3	1只 1 Pc
4	2只 2 Pc
	無 SENSOR No Sensor
5	無 SENSOR No Sensor

馬達廠牌 Motor Brand

MB-3M	含电机，厂家安装三菱帶制动车电机，线长3米
ZMB	不含电机，客户自己安装三菱帶制动车电机
KMB	不含电机，客户提供三菱帶制动车电机，厂家安装

※若無煞車則B不表示。
※If No Brake, No B Description.

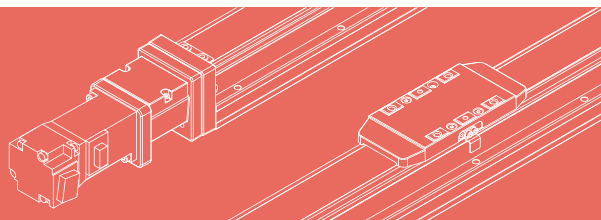

基本仕様 Specification

規格 Spec	位置重複精度 Repeatability (mm)	±0.01				
	螺桿導程 Ball Screw Lead (mm)	2	5	10	20	
	最高速度 Maximum Speed (mm/s)	100	250	500	1000	
	最大可搬重量 Maximum Payload	水平使用 Horizontal (kg)	30	30	15	10
		垂直使用 Vertical (kg)	10	10	5	2.5
	定格推力 Rated Thrust (N)	854	341	170	85	
標準行程 Stroke Pitch (mm)	50-800mm/50間隔 50 mm Pitch					
部品 Parts	AC伺服馬達容量 AC Servo Motor Output (W)	100				
	滾珠螺桿外徑 Ball Screw Ø (mm)	C7 φ 12				
	連軸器 Coupling (mm)	7X8				
	原點感應器 Home Sensor	外掛 Outside	EE-SX674(NPN) FC-SPX307Z-2M(NPN)			

※行程超過600時，會產生螺桿偏擺，此時請將速度調降。
When the stroke is over 600mm, the run-out of the ballscrew will occur.
We recommend to low down the working speed under this circumstances.

※馬達加減速設定0.2秒。
Acceleration and deceleration value is set 0.2 second.

感應器接線圖<原點及端點> Sensor Layout

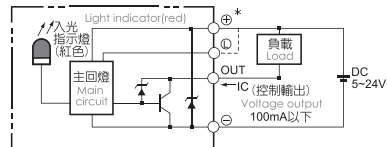

容許負載力距表 Allowable Overhang

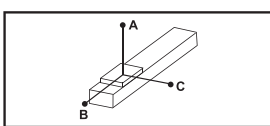

(單位 Unit : mm)

水平安裝 Horizontal Installation	A	B	C	
導程 2 Lead	10kg	900	100	135
	20kg	700	45	60
	30kg	550	25	35
導程 5 Lead	10kg	650	75	100
	20kg	440	32	45
	30kg	270	19	25
導程 10 Lead	5kg	600	145	185
	10kg	370	70	85
	15kg	250	42	52
導程 20 Lead	5kg	320	120	130
	8kg	220	70	80
	10kg	175	55	60

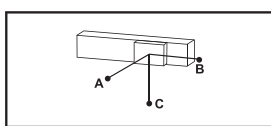

(單位 Unit : mm)

壁掛安裝 Wall Installation	A	B	C	
導程 2 Lead	10kg	135	100	900
	20kg	60	45	700
	30kg	37	27	550
導程 5 Lead	10kg	100	75	650
	20kg	45	32	420
	30kg	25	19	260
導程 10 Lead	5kg	180	145	600
	10kg	85	68	370
	15kg	52	42	250
導程 20 Lead	5kg	130	120	320
	8kg	75	70	220
	10kg	60	55	170

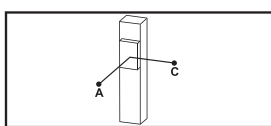

(單位 Unit : mm)

垂直安裝 Vertical Installation	A	C	
導程 2 Lead	6kg	180	180
	8kg	135	135
	10kg	110	110
導程 5 Lead	6kg	145	145
	8kg	110	110
	10kg	90	90
導程 10 Lead	1kg	800	800
	3kg	260	260
	5kg	155	155
導程 20 Lead	1kg	600	600
	2kg	300	300
	2.5kg	250	250

靜態容許負載慣量 Static Loading Moment

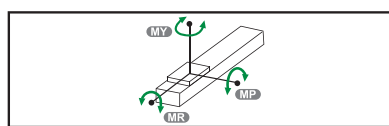

(單位 Unit : N.m)

MY	103
MP	103
MR	144

※力距表所表示的數據，代表重心。
The torque value in the chart indicate the center of gravity.
※符合型錄規範的正常使用下，保證壽命為10000公里。
Operation life is 10,000km when the product is using under the specified conditions.
※倒吊使用無法套用標準規範，如有需求請洽詢我司業務。
Data information is not for ceiling-mount inverse use.
Contact us for the details if you want to apply ceiling-mount inverse usage.

搭配伺服馬達一覽表 Suitable Motor Brand

廠牌 Brand	馬達記號 Mark	煞車有無 Brake	馬達容量 Watt	電源電壓 AC-Voltage	伺服馬達型號 Motor Model	驅動器型號 Driver Model
三菱 Mitsubishi	M	無煞車(水平仕様) No Brake (Horizontal Type)	100	220	HG-KN13J-S100	MR-JE-10A
		有煞車(垂直仕様) With Brake (Vertical Type)	100	220	HG-KN13BJ-S100	MR-JE-10A
松下 Panasonic	P	無煞車(水平仕様) No Brake (Horizontal Type)	100	220	MSMF012L1U2M	MADLN05SE
		有煞車(垂直仕様) With Brake (Vertical Type)	100	220	MSMF012L1V2M	MADLN05SE
台達 Delta	T	無煞車(水平仕様) No Brake (Horizontal Type)	100	220	ECM-B3L-C20401RS1	ASD-B3-0121-L
		有煞車(垂直仕様) With Brake (Vertical Type)	100	220	ECM-B3L-C20401SS1	ASD-B3-0121-L

JGS5 單軸/1-axis

▶ 軌道內嵌 ▶ 螺桿驅動
Built-in Guideway Ball Screw Drive

馬達外露/馬達下折

Motor Exposed / Motor Bottom Side

BC 馬達外露 Motor Exposed



單位 Unit : mm

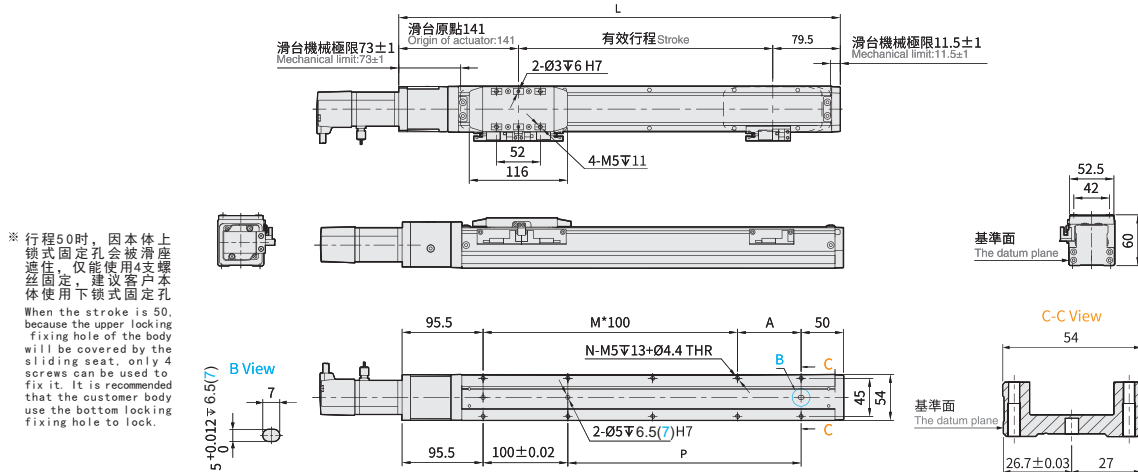

* 行程50时，因本體上鎖式固定孔會被滑座遮擋，僅能使用4支螺絲固定，建議客戶本體使用下鎖式固定孔。When the stroke is 50, because the upper locking fixing hole of the body will be covered by the sliding seat, only 4 screws can be used to fix it. It is recommended that the customer body use the bottom locking fixing hole to lock.

有效行程 Stroke	50	100	150	200	250	300	350	400	450	500	550	600	650	700	750	800
L	270.5	320.5	370.5	420.5	470.5	520.5	570.5	620.5	670.5	720.5	770.5	820.5	870.5	920.5	970.5	1020.5
A	25	75	25	75	25	75	25	75	25	75	25	75	25	75	25	75
M	1	1	2	2	3	3	4	4	5	5	6	6	7	7	8	8
N	6	6	8	8	10	10	12	12	14	14	16	16	18	18	20	20
P	25	75	125	175	225	275	325	375	425	475	525	575	625	675	725	775
KG	1.65	1.79	1.92	2.11	2.39	2.50	2.52	2.75	2.86	2.95	3.15	3.28	3.44	3.58	3.71	4.09

BM 馬達下折 Motor Bottom Side



單位 Unit : mm

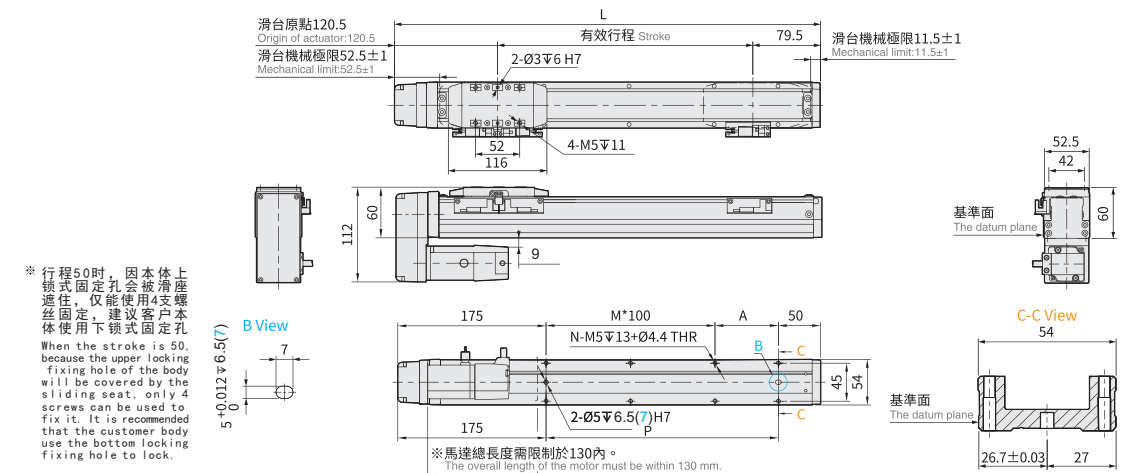

* 行程50时，因本體上鎖式固定孔會被滑座遮擋，僅能使用4支螺絲固定，建議客戶本體使用下鎖式固定孔。When the stroke is 50, because the upper locking fixing hole of the body will be covered by the sliding seat, only 4 screws can be used to fix it. It is recommended that the customer body use the bottom locking fixing hole to lock.



※馬達總長度需限制於130mm內。
The overall length of the motor must be within 130 mm.

有效行程 Stroke	50	100	150	200	250	300	350	400	450	500	550	600	650	700	750	800
L	250	300	350	400	450	500	550	600	650	700	750	800	850	900	950	1000
A	25	75	25	75	25	75	25	75	25	75	25	75	25	75	25	75
M	0	0	1	1	2	2	3	3	4	4	5	5	6	6	7	7
N	4	4	6	6	8	8	10	10	12	12	14	14	16	16	18	18
P	25	75	125	175	225	275	325	375	425	475	525	575	625	675	725	775
KG	1.68	1.80	2.03	2.14	2.42	2.53	2.58	2.78	2.89	2.98	3.18	3.31	3.47	3.60	3.74	4.12

※馬達下折時，若選用煞車馬達，或是超出馬達總長度限制時無法套用標準PIN孔，如有需求請洽我司業務。
When motor with brake assembled on lower side, or the total length over than spec limit, it may not use standard pinhole. Please contact our sales department if you need more information & requirement.

馬達左折/馬達右折

Motor Left Side / Motor Right Side

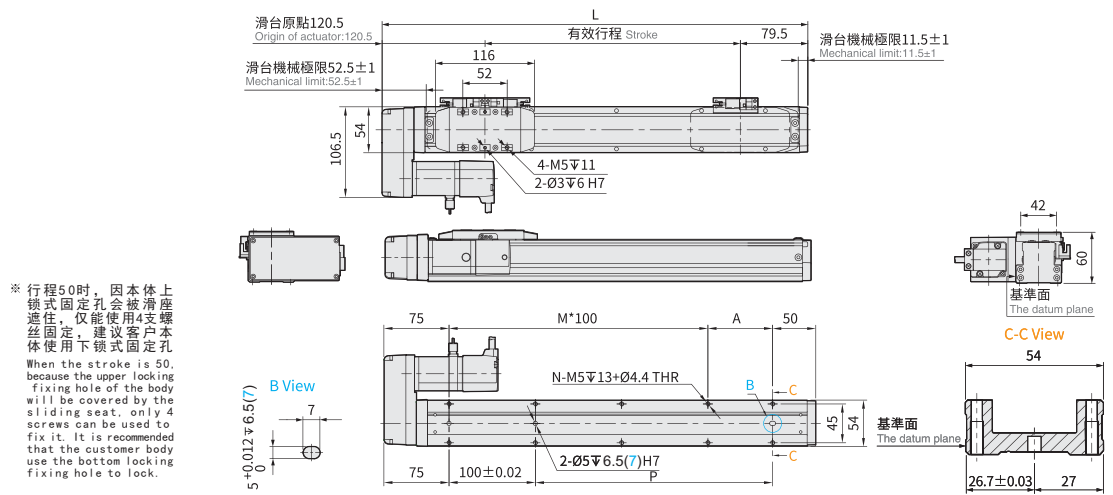

BL 馬達左折 Motor Left Side  

單位 Unit : mm



* 行程50時，因本體上鎖式固定孔會被滑座遮住，僅能使用4支螺絲固定，建議客戶本體使用下鎖式固定孔
When the stroke is 50, because the upper locking fixing hole of the body will be covered by the sliding seat, only 4 screws can be used to fix it. It is recommended that the customer body use the bottom locking fixing hole to lock.

有效行程 Stroke	50	100	150	200	250	300	350	400	450	500	550	600	650	700	750	800
L	250	300	350	400	450	500	550	600	650	700	750	800	850	900	950	1000
A	25	75	25	75	25	75	25	75	25	75	25	75	25	75	25	75
M	1	1	2	2	3	3	4	4	5	5	6	6	7	7	8	8
N	6	6	8	8	10	10	12	12	14	14	16	16	18	18	20	20
P	25	75	125	175	225	275	325	375	425	475	525	575	625	675	725	775
KG	1.68	1.80	2.03	2.14	2.42	2.53	2.58	2.78	2.89	2.98	3.18	3.31	3.47	3.60	3.74	4.12

BR 馬達右折 Motor Right Side  

單位 Unit : mm

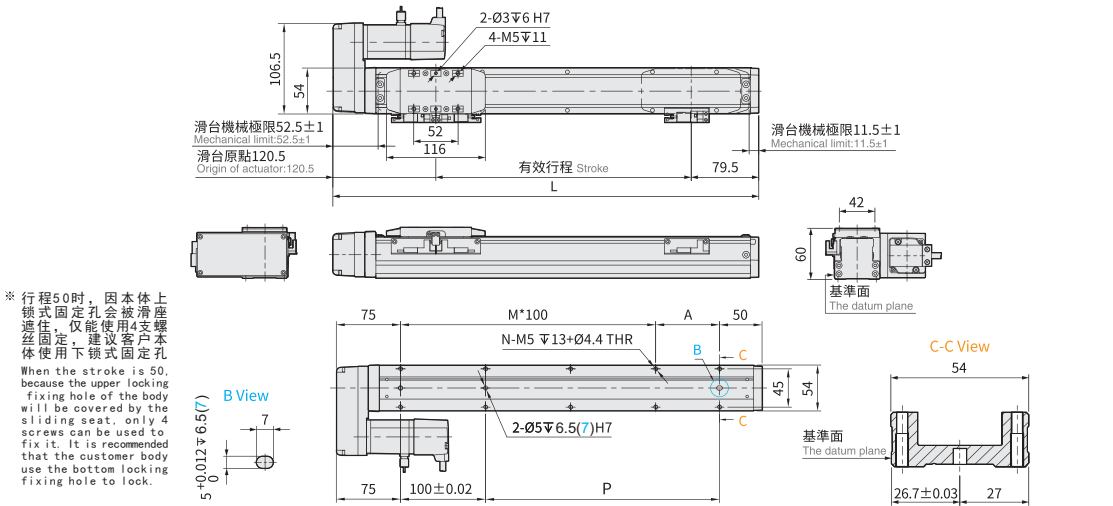

* 行程50時，因本體上鎖式固定孔會被滑座遮住，僅能使用4支螺絲固定，建議客戶本體使用下鎖式固定孔
When the stroke is 50, because the upper locking fixing hole of the body will be covered by the sliding seat, only 4 screws can be used to fix it. It is recommended that the customer body use the bottom locking fixing hole to lock.

有效行程 Stroke	50	100	150	200	250	300	350	400	450	500	550	600	650	700	750	800
L	250	300	350	400	450	500	550	600	650	700	750	800	850	900	950	1000
A	25	75	25	75	25	75	25	75	25	75	25	75	25	75	25	75
M	1	1	2	2	3	3	4	4	5	5	6	6	7	7	8	8
N	6	6	8	8	10	10	12	12	14	14	16	16	18	18	20	20
P	25	75	125	175	225	275	325	375	425	475	525	575	625	675	725	775
KG	1.68	1.80	2.03	2.14	2.42	2.53	2.58	2.78	2.89	2.98	3.18	3.31	3.47	3.60	3.74	4.12