

JGB12 400W伺服電機

單軸/1-axis

▶ 軌道內嵌
Built-in Guideway

▶ 皮帶驅動
Belt Drive

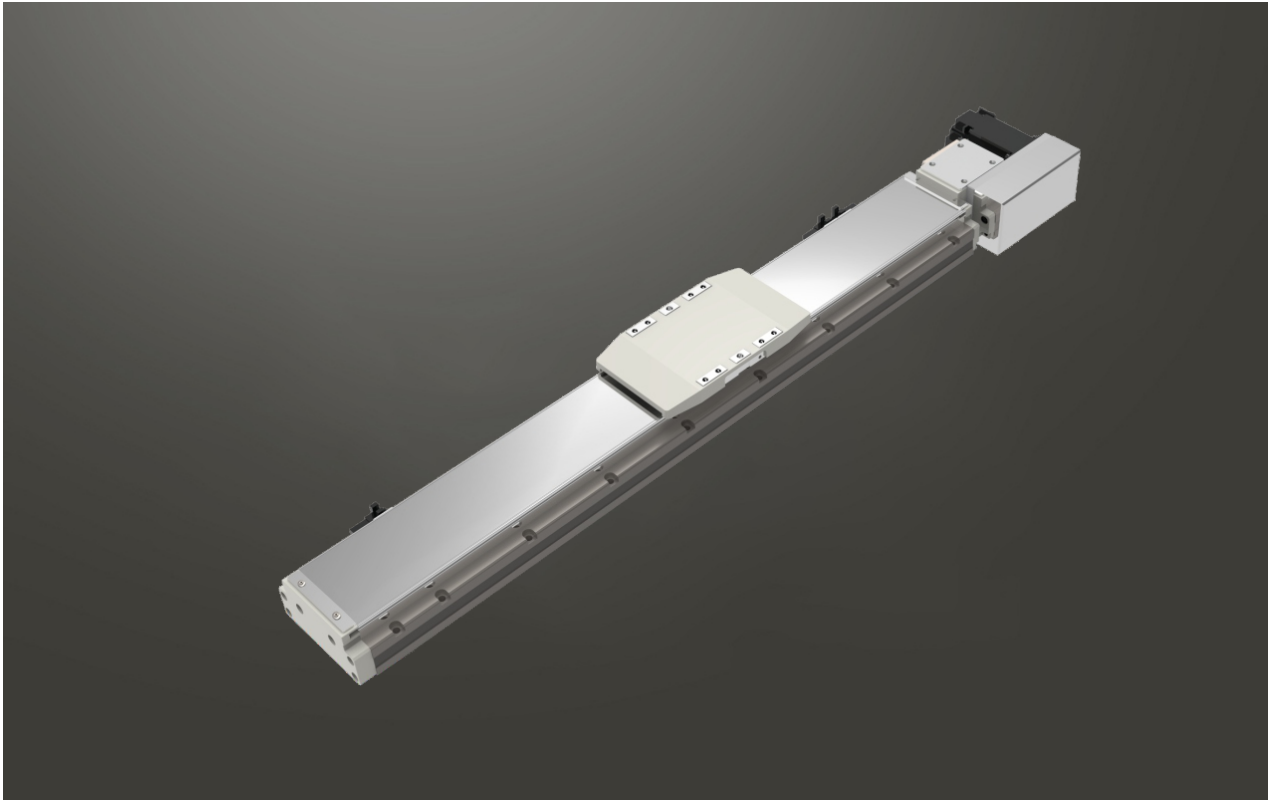

此圖僅供參考，出貨規格詳見尺寸圖面
The picture is just for the reference. Please check the the actual dimensions on the drawing.

最大行程
Maximum Stroke **1200mm**

最高速度
Maximum Speed **2000mm/s**

馬達容量
Motor Output **400W**

皮帶寬度
Belt Width **22mm**

型號表示方式 Ordering Method

JGB12 - L40 - 100 - BL - T400W - C 4 - MB-3M

本體型號
Model

導程
Lead

40 40mm

行程
Stroke

100-1200mm
50間隔 50 mm Pitch

馬達位置
Motor Position

BL	馬達左折 Motor Left Side
LU	馬達左上折 Motor Left Upper Side
LD	馬達左下折 Motor Left Lower Side
BR	馬達右折 Motor Right Side
RU	馬達右上折 Motor Right Upper Side
RD	馬達右下折 Motor Right Lower Side

電機安裝標準
Motor installation

T	通用马达安装标准:
	三菱 Mitsubishi
	台達 Delta
	安川 Yaskawa
	汇川 Inovance
	等等 Etc
P	松下马达安装标准

馬達容量
Motor Output

100W	-
200W	-
400W	400W

原點感應器
Home Sensor

	外掛型 Out Side
C	馬達側 Motor Side
D	反馬達側 Opposite Motor Side
	無 SENSOR No Sensor
E	無 SENSOR No Sensor

端點極限感應器
Limit Sensor

	外掛型 Out Side
3	1只 1 Pc
4	2只 2 Pc
	無 SENSOR No Sensor
5	無 SENSOR No Sensor

馬達廠牌
Motor Brand

MB-3M	含电机, 厂家安装三菱带刹车电机, 线长3米
ZMB	不含电机, 客户自己安装三菱带刹车电机
KMB	不含电机, 客户提供三菱带刹车电机, 厂家安装

※若無煞車則B不表示。
※If No Brake, No B Description.

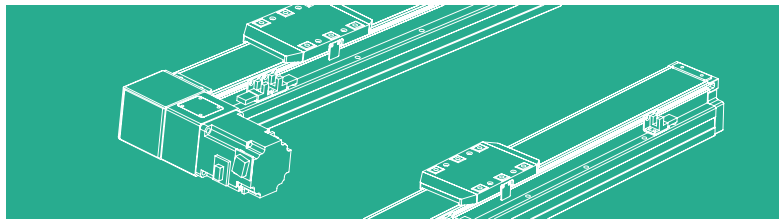

基本仕様 Specification

規格 Spec	位置重複精度 Repeatability (mm)	±0.04		
	導程 Lead (mm)	40		
	最高速度 Maximum Speed (mm/s)	2000		
	最大可搬重量 Maximum Payload	水平使用 Horizontal (kg)	25	
		垂直使用 Vertical (kg)		
	定格推力 Rated Thrust (N)	100		
標準行程 Stroke Pitch (mm)	100-1200mm/50間隔 50 mm Pitch			
部品 Parts	AC伺服馬達容量 AC Servo Motor Output (W)	400		
	皮帶寬度 Belt Width	22		
	原點感應器 Home Sensor	外掛 Outside	EE-SX674(NPN) FC-SPX307Z-2M(NPN)	

*馬達加減速設定0.4秒。
Acceleration and deacceleration value is set 0.4 second.

感應器接線圖 <原點及端點> Sensor Layout

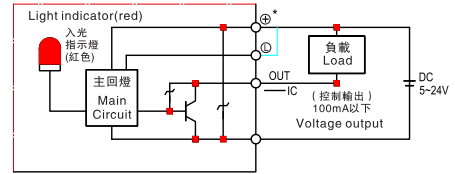

*馬達加減速設定0.4秒
*Acceleration and deacceleration value is set 0.4 second.
*帶減速比1: 2.5

容許負載力距表 Allowable Overhang

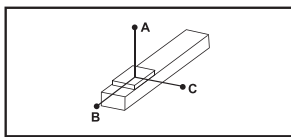

(單位 Unit : mm)

水平安裝 Horizontal Installation	A	B	C
10kg	1885	735	564
20kg	900	340	265
25kg	703	303	206

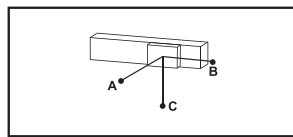

(單位 Unit : mm)

壁掛安裝 Wall Installation	A	B	C
10kg	365	458	1280
20kg	299	383	1009
25kg	206	263	703

*力距表所表示的數據，代表重心。
The torque value in the chart indicate the center of gravity.
*符合型錄規範的正常使用下，保證壽命為10000公里。
Operation life is 10,000km when the product is using under the specified conditions.
*倒吊使用無法套用標準規範，如有需求請洽詢我司業務。
Data information is not for ceiling-mount inverse use.
Contact us for the details if you want to apply ceiling-mount inverse usage.

靜態容許負載慣量 Static Loading Moment

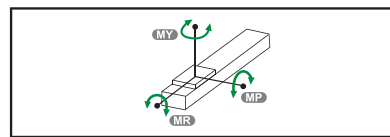

(單位 Unit : N.m)

MY	606
MP	606
MR	1168

搭配伺服馬達一覽表 Suitable Motor Brand

廠牌 Brand	馬達記號 Mark	煞車有無 Brake	馬達容量 Watt	電源電壓 AC-Voltage	伺服馬達型號 Motor Model	驅動器型號 Driver Model
三菱 Mitsubishi	M	無煞車(水平仕様) No Brake (Horizontal Type)	400	220	HG-KN43J-S100	MR-JE-40A
松下 Panasonic	P	無煞車(水平仕様) No Brake (Horizontal Type)	400	220	MHMF042L1U2M	MBDLN25SE
台達 Delta	T	無煞車(水平仕様) No Brake (Horizontal Type)	400	220	ECM-B3M-C20604RS1	ASD-B3-0421-L

JGB12 單軸/1-axis

▶ 軌道內嵌
Built-in Guideway

▶ 皮帶驅動
Belt Drive

馬達左折/馬達右折

Motor Left Side / Motor Right Side

BL 馬達左折 Motor Left Side



單位 Unit: mm

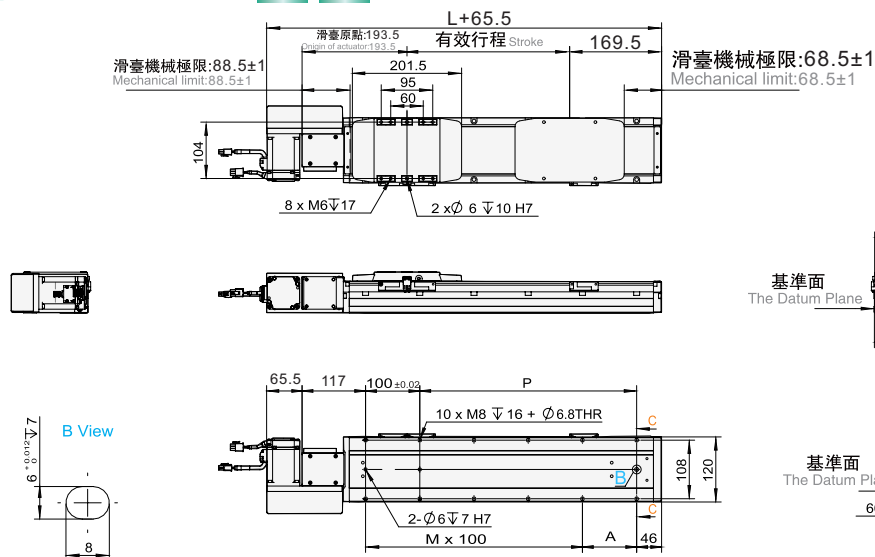

有效行程 Stroke	100	150	200	250	300	350	400	450	500	550	600	650	700	750	800	850	900	950	1000	1050	1100	1150	1200
L	463	513	563	613	663	713	763	813	863	913	963	1013	1063	1113	1163	1213	1263	1313	1363	1413	1463	1513	1563
A	100	50	100	50	100	50	100	50	100	50	100	50	100	50	100	50	100	50	100	50	100	50	100
M	2	3	3	4	4	5	5	6	6	7	7	8	8	9	9	10	10	11	11	12	12	13	13
N	8	10	10	12	12	14	14	16	16	18	18	20	20	22	22	24	24	26	26	28	28	30	30
P	200	250	300	350	400	450	500	550	600	650	700	750	800	850	900	950	1000	1050	1100	1150	1200	1250	1300
KG	6.34	6.70	7.06	7.42	7.78	8.13	8.49	8.85	9.21	9.57	9.92	10.28	10.64	11.00	11.36	11.71	12.07	12.43	12.79	13.15	13.50	13.86	14.22

BR 馬達右折 Motor Right Side



單位 Unit: mm

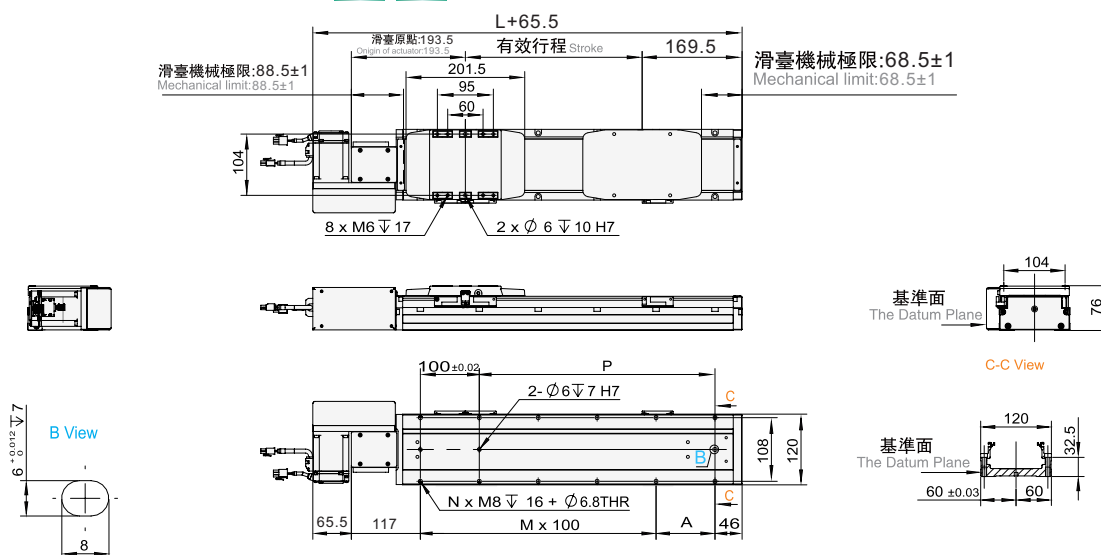

有效行程 Stroke	100	150	200	250	300	350	400	450	500	550	600	650	700	750	800	850	900	950	1000	1050	1100	1150	1200
L	463	513	563	613	663	713	763	813	863	913	963	1013	1063	1113	1163	1213	1263	1313	1363	1413	1463	1513	1563
A	100	50	100	50	100	50	100	50	100	50	100	50	100	50	100	50	100	50	100	50	100	50	100
M	2	3	3	4	4	5	5	6	6	7	7	8	8	9	9	10	10	11	11	12	12	13	13
N	8	10	10	12	12	14	14	16	16	18	18	20	20	22	22	24	24	26	26	28	28	30	30
P	200	250	300	350	400	450	500	550	600	650	700	750	800	850	900	950	1000	1050	1100	1150	1200	1250	1300
KG	6.34	6.70	7.06	7.42	7.78	8.13	8.49	8.85	9.21	9.57	9.92	10.28	10.64	11.00	11.36	11.71	12.07	12.43	12.79	13.15	13.50	13.86	14.22

馬達左上折/馬達右上折

Motor Left Upper Side / Motor Right Upper Side



馬達左上折 Motor Left Upper Side



單位 Unit : mm

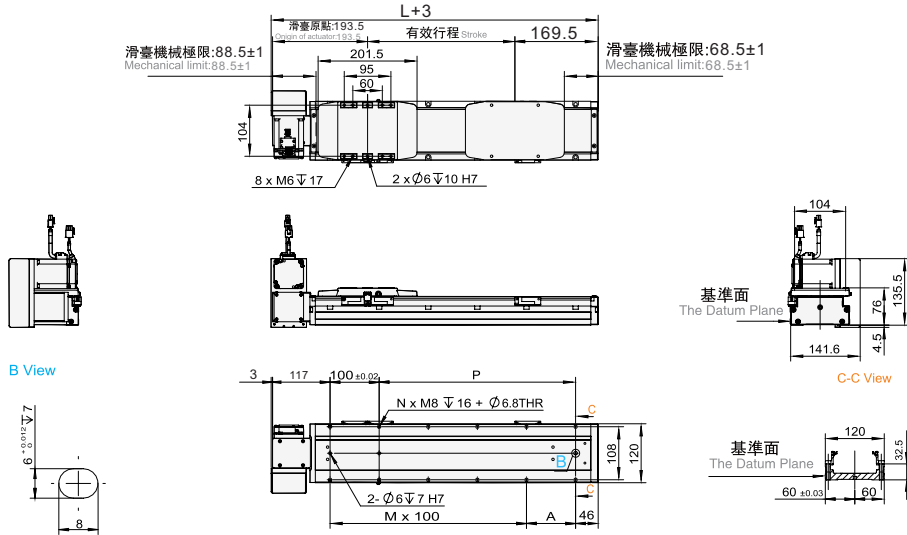

有效行程 Stroke	100	150	200	250	300	350	400	450	500	550	600	650	700	750	800	850	900	950	1000	1050	1100	1150	1200
L	463	513	563	613	663	713	763	813	863	913	963	1013	1063	1113	1163	1213	1263	1313	1363	1413	1463	1513	1563
A	100	50	100	50	100	50	100	50	100	50	100	50	100	50	100	50	100	50	100	50	100	50	100
M	2	3	3	4	4	5	5	6	6	7	7	8	8	9	9	10	10	11	11	12	12	13	13
N	8	10	10	12	12	14	14	16	16	18	18	20	20	22	22	24	24	26	26	28	28	30	30
P	200	250	300	350	400	450	500	550	600	650	700	750	800	850	900	950	1000	1050	1100	1150	1200	1250	1300
KG	6.34	6.70	7.06	7.42	7.78	8.13	8.49	8.85	9.21	9.57	9.92	10.28	10.64	11.00	11.36	11.71	12.07	12.43	12.79	13.15	13.50	13.86	14.22



馬達右上折 Motor Right Upper Side



單位 Unit : mm

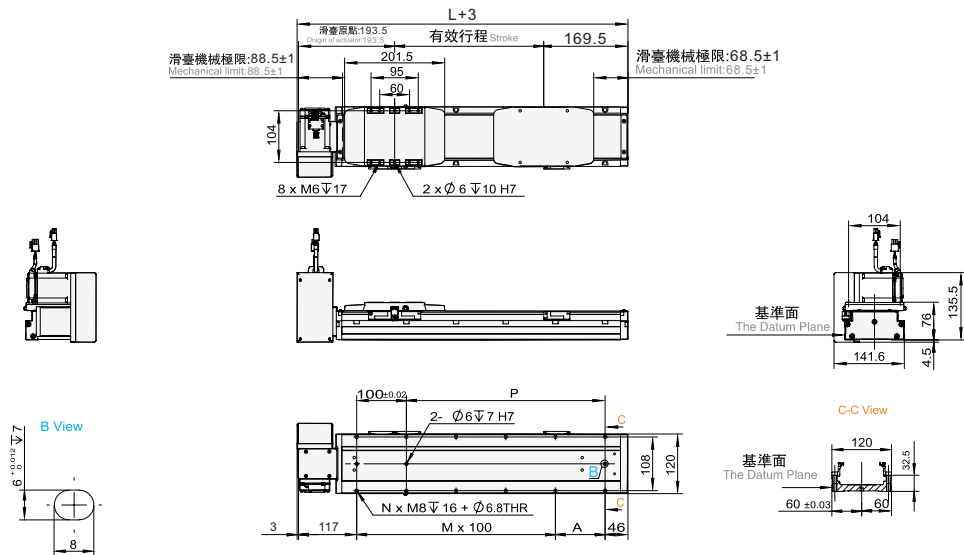

有效行程 Stroke	100	150	200	250	300	350	400	450	500	550	600	650	700	750	800	850	900	950	1000	1050	1100	1150	1200
L	463	513	563	613	663	713	763	813	863	913	963	1013	1063	1113	1163	1213	1263	1313	1363	1413	1463	1513	1563
A	100	50	100	50	100	50	100	50	100	50	100	50	100	50	100	50	100	50	100	50	100	50	100
M	2	3	3	4	4	5	5	6	6	7	7	8	8	9	9	10	10	11	11	12	12	13	13
N	8	10	10	12	12	14	14	16	16	18	18	20	20	22	22	24	24	26	26	28	28	30	30
P	200	250	300	350	400	450	500	550	600	650	700	750	800	850	900	950	1000	1050	1100	1150	1200	1250	1300
KG	6.34	6.70	7.06	7.42	7.78	8.13	8.49	8.85	9.21	9.57	9.92	10.28	10.64	11.00	11.36	11.71	12.07	12.43	12.79	13.15	13.50	13.86	14.22

JGB12 單軸/1-axis

▶ 軌道內嵌
Built-in Guideway

▶ 皮帶驅動
Belt Drive

馬達左下折/馬達右下折

Motor Left Lower Side / Motor Right Lower Side

LD 馬達左下折 Motor Left Lower Side



單位 Unit: mm

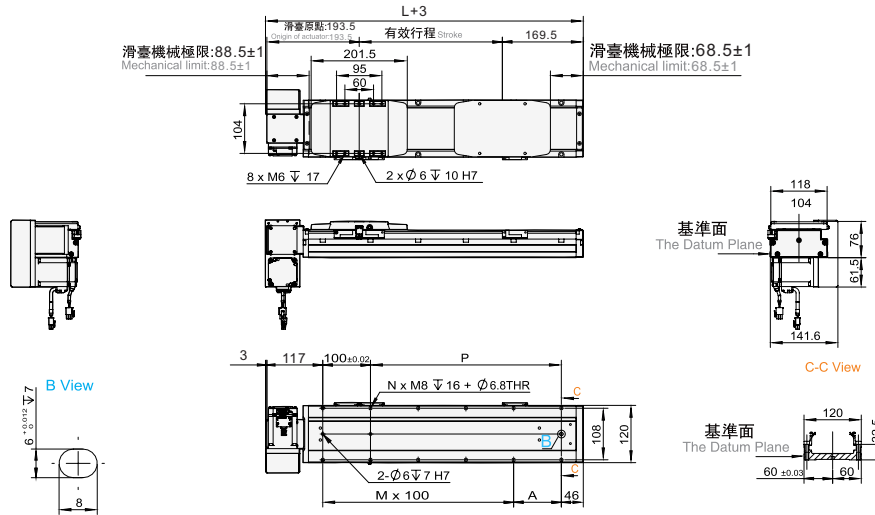

有效行程 Stroke	100	150	200	250	300	350	400	450	500	550	600	650	700	750	800	850	900	950	1000	1050	1100	1150	1200
L	463	513	563	613	663	713	763	813	863	913	963	1013	1063	1113	1163	1213	1263	1313	1363	1413	1463	1513	1563
A	100	50	100	50	100	50	100	50	100	50	100	50	100	50	100	50	100	50	100	50	100	50	100
M	2	3	3	4	4	5	5	6	6	7	7	8	8	9	9	10	10	11	11	12	12	13	13
N	8	10	10	12	12	14	14	16	16	18	18	20	20	22	22	24	24	26	26	28	28	30	30
P	200	250	300	350	400	450	500	550	600	650	700	750	800	850	900	950	1000	1050	1100	1150	1200	1250	1300
KG	6.34	6.70	7.06	7.42	7.78	8.13	8.49	8.85	9.21	9.57	9.92	10.28	10.64	11.00	11.36	11.71	12.07	12.43	12.79	13.15	13.50	13.86	14.22

RD 馬達右下折 Motor Right Lower Side



單位 Unit: mm

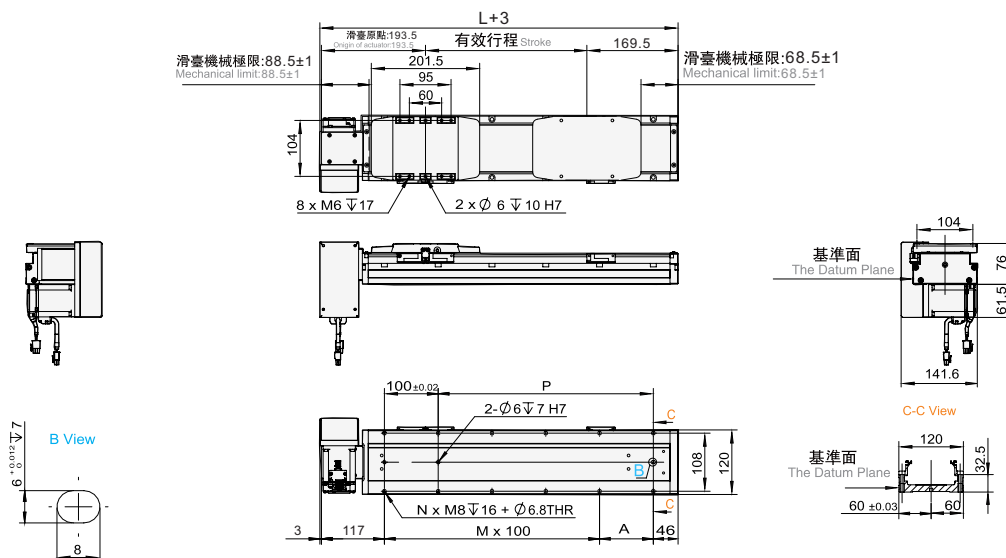

有效行程 Stroke	100	150	200	250	300	350	400	450	500	550	600	650	700	750	800	850	900	950	1000	1050	1100	1150	1200
L	463	513	563	613	663	713	763	813	863	913	963	1013	1063	1113	1163	1213	1263	1313	1363	1413	1463	1513	1563
A	100	50	100	50	100	50	100	50	100	50	100	50	100	50	100	50	100	50	100	50	100	50	100
M	2	3	3	4	4	5	5	6	6	7	7	8	8	9	9	10	10	11	11	12	12	13	13
N	8	10	10	12	12	14	14	16	16	18	18	20	20	22	22	24	24	26	26	28	28	30	30
P	200	250	300	350	400	450	500	550	600	650	700	750	800	850	900	950	1000	1050	1100	1150	1200	1250	1300
KG	6.34	6.70	7.06	7.42	7.78	8.13	8.49	8.85	9.21	9.57	9.92	10.28	10.64	11.00	11.36	11.71	12.07	12.43	12.79	13.15	13.50	13.86	14.22